

NVS-RNS TYPE

—Special Environments Type—

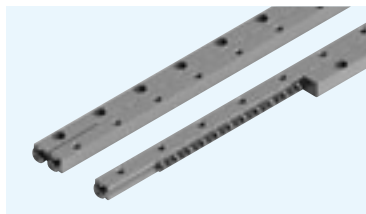

part number structure

example **NVS 4 200-RNS 27Z - P**

specification
NVS: anti-corrosion

size

accuracy grade
blank: high
P: precision
UP: ultra precision

number of rollers

cage type
RNS: stainless steel cage
stainless steel roller
RN: stainless steel cage
standard roller

rail length

part number	stroke ST mm	roller diameter D mm	number of rollers Z	major dimensions												
				L mm	A mm	B mm	C mm	M×P mm	N mm	E mm						
NVS 2030-RNS 7Z	15	2	7	30	12	6	5.7	1×15	7.5	2.5						
2045-RNS11Z	20		11	45				2×15								
2060-RNS13Z	30		13	60				3×15								
2075-RNS17Z	40		17	75				4×15								
2090-RNS21Z	50		21	90				5×15								
2105-RNS23Z	65		23	105				6×15								
2120-RNS27Z	70		27	120				7×15								
2135-RNS31Z	80		31	135				8×15								
2150-RNS33Z	90		33	150				9×15								
2165-RNS37Z	95		37	165				10×15								
2180-RNS43Z	100		43	180				11×15								
NVS 3050-RNS 9Z	20	3	9	50	18	8	8.65	1×25	12.5	3.5						
3075-RNS13Z	38		13	75				2×25								
3100-RNS17Z	55		17	100				3×25								
3125-RNS21Z	70		21	125				4×25								
3150-RNS25Z	85		25	150				5×25								
3175-RNS29Z	103		29	175				6×25								
3200-RNS33Z	113		33	200				7×25								
3225-RNS35Z	150		35	225				8×25								
NVS 4080-RNS 9Z	58		4	9				80			22	11	10.65	1×40	20	4.5
4120-RNS17Z	60			17				120						2×40		
4160-RNS21Z	98	21		160	3×40											
4200-RNS27Z	115	27		200	4×40											
4240-RNS31Z	143	31		240	5×40											
4280-RNS37Z	170	37		280	6×40											

※Some specification values are different from those of NV standard type. Please contact NB for details.

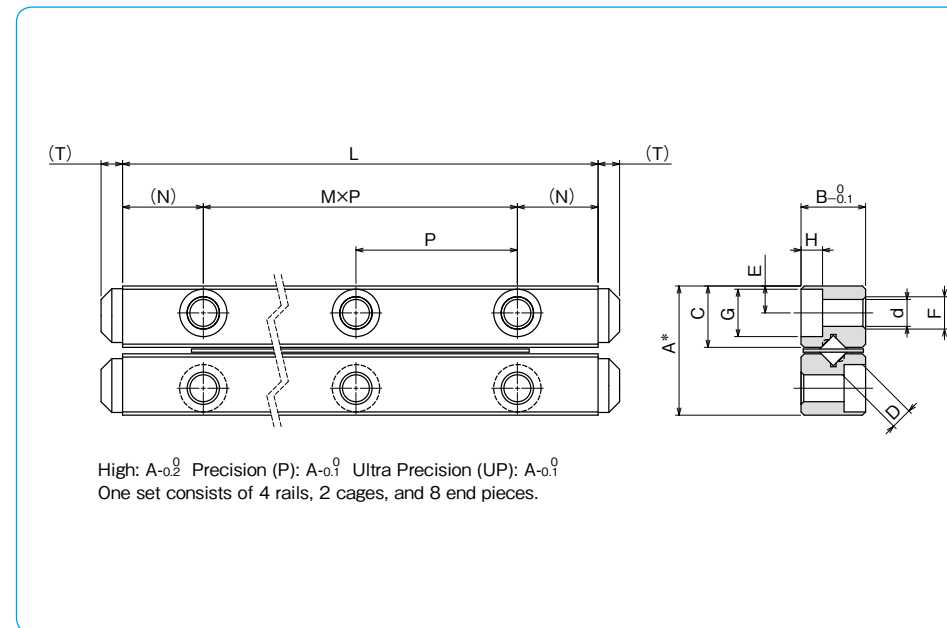

F	d mm	G mm	H mm	T mm	basic load rating		allowable load F N	mass (one set) g	size
					dynamic C N	static Co N			
M3	2.55	4.4	2	1.2	2,320	3,050	1,010	30	2030
					3,190	4,580	1,520	44	2045
					3,190	4,580	1,520	58	2060
					4,000	6,110	2,030	73	2075
					4,760	7,630	2,540	87	2090
					5,490	9,160	3,050	101	2105
					6,190	10,600	3,560	115	2120
					6,870	12,200	4,070	130	2135
					6,870	12,200	4,070	144	2150
					7,530	13,700	4,580	158	2165
M4	3.3	6	3.1	2	8,800	16,800	5,600	173	2180
					6,150	8,060	2,680	102	3050
					8,460	12,100	4,030	151	3075
					10,600	16,100	5,370	200	3100
					12,600	20,100	6,720	249	3125
					14,500	24,200	8,060	297	3150
					16,400	28,200	9,410	346	3175
					18,200	32,200	10,700	395	3200
					19,900	36,300	12,100	443	3225
					12,100	15,700	5,250	269	4080
M5	4.3	8	4.2	2	20,800	31,500	10,500	405	4120
					24,800	39,300	13,100	536	4160
					32,200	55,100	18,300	670	4200
					35,800	63,000	21,000	801	4240
					39,200	70,900	23,600	935	4280