

# TRKC TYPE

— Triple-Wide Intermediate Position Square Flange Type —

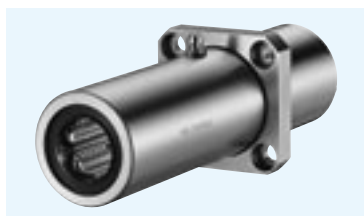

## part number structure

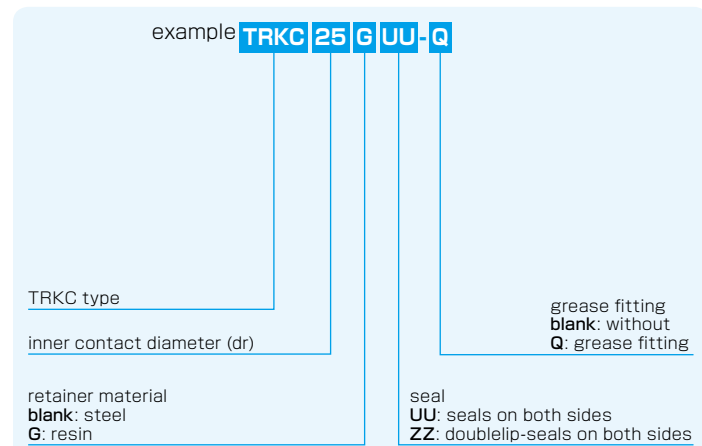

Doublelip-seal is available for size 6 to 30.

part number*		number of ball circuits	dr		major dimensions		
steel retainer	resin retainer		mm	tolerance $\mu\text{m}$	D	tolerance $\mu\text{m}$	L $\pm 0.3$ mm
TRKC 6UU	TRKC 6GUU	4	6		15	0/-18	51
TRKC 8UU	TRKC 8GUU	4	8	0	19		66
TRKC 10UU	TRKC 10GUU	4	10	-12	23	0	80
TRKC 12UU	TRKC 12GUU	4	12		26	-21	84
TRKC 13UU	TRKC 13GUU	4	13	0	28		90
TRKC 16UU	TRKC 16GUU	4	16	-15	32		103
TRKC 20UU	TRKC 20GUU	5	20		40	0	118
TRKC 25UU	TRKC 25GUU	6	25	0	45	-25	165
TRKC 30UU	TRKC 30GUU	6	30	-18	52		182
TRKC 35UU	TRKC 35GUU	6	35		60	0	200
TRKC 40UU	TRKC 40GUU	6	40	0	65	-30	230
TRKC 50UU	TRKC 50GUU	6	50	-21	85	0	290
TRKC 60UU	TRKC 60GUU	6	60	0/-25	100	-35	310

Outer cylinder is treated with electroless nickel plating.

\* Seals-on-both-sides is standard.

\*\* TRKC6: A-MT6x1 TRKC8: A-M6x1 TRKC10~30: A-M6F TRKC35~60: A-R1/8

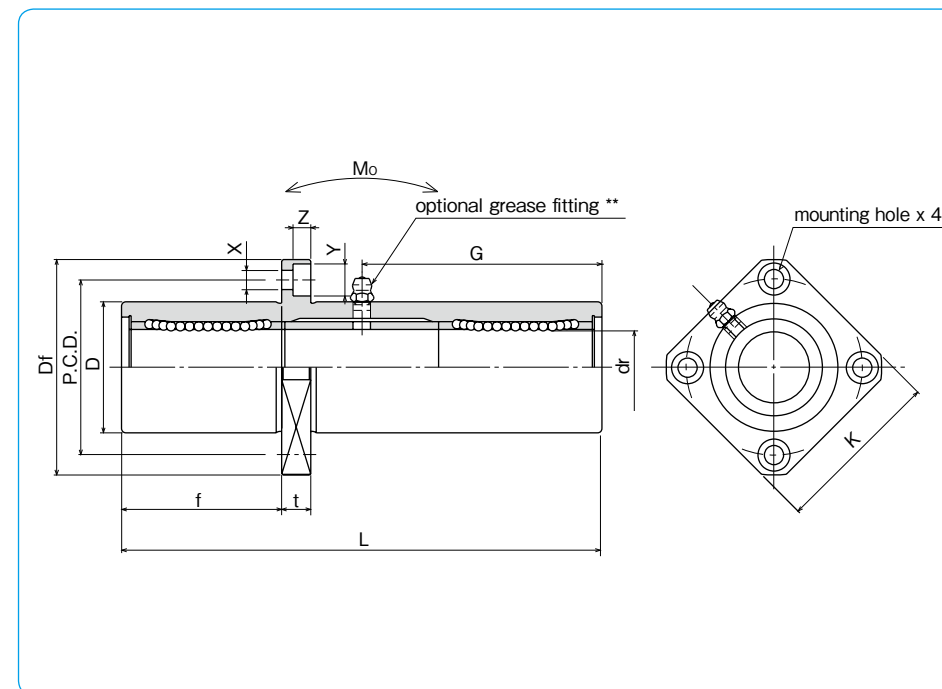

f mm	Df mm	flange			P.C.D. mm	X×Y×Z mm	grease fitting G mm	eccentricity $\mu\text{m}$	perpendicularity $\mu\text{m}$	basic load rating		allowable static moment Mo N·m	mass g	shaft diameter mm
		K mm	t mm	C N						Co N				
17	32	25	5	24	3.5×6×3.1	20.5	20	20	323	530	8.2	58	6	
22	40	30	6	29	4.5×7.5×4.1	29			431	784	16.0	117	8	
27	43	34	6	33	4.5×7.5×4.1	38			588	1,100	27.0	189	10	
28	46	35	6	36	4.5×7.5×4.1	41			813	1,570	40.1	228	12	
30	48	37	6	38	4.5×7.5×4.1	45			813	1,570	42.9	286	13	
35	54	42	8	43	5.5×9×5.1	51	25	25	1,230	2,350	73.5	376	16	
40	62	50	8	51	5.5×9×5.1	59			1,400	2,740	98.0	714	20	
55	74	58	10	60	6.6×11×6.1	82.5			1,560	3,140	157	1,163	25	
61	82	64	10	67	6.6×11×6.1	91			2,490	5,490	297	1,543	30	
67	96	75	13	78	9×14×8.1	100			2,650	6,270	373	2,400	35	
77	101	80	13	83	9×14×8.1	115	30	30	3,430	8,040	553	2,510	40	
97	129	100	18	107	11×17×11.1	145			6,080	15,900	1,370	6,400	50	
104	144	116	18	122	11×17×11.1	155			7,550	20,000	1,800	9,200	60	

1N  $\approx$  0.102kgf 1N · m  $\approx$  0.102kgf · m