

TQK-E TYPE

– Square Flange Type with Pilot End –



part number structure

example) **TQK 25 G UU-E-SK**

TQK type	25	G	UU	E	SK
inner contact diameter (dr)					
resin retainer					
					with pilot end
					outer cylinder surface treatment
					blank: no surface treatment
					SK: electroless nickel plating
					LF: low temperature black chrome treatment with fluoride coating
					SB: black oxide
					SC: industrial chrome plating
					seal
					UU: seals on both sides
					ZZ: doublelip-seals on both sides

Doublelip-seal is available for size 6 to 30.

part number*	number of ball circuits	dr		D		major dimensions					
		mm	tolerance μm	mm	tolerance μm	L ± 0.3 mm	f mm	Df mm	K mm	t mm	flange P.C.D. mm
TQK16GUU-E	4	16	0/-9	32	0	37	8	54	42	8	43
TQK20GUU-E	5	20	0	40	-19	42	8	62	50	8	51
TQK25GUU-E	6	25	-10	45	0	59	10	74	58	10	60
TQK30GUU-E	6	30	0	52	-22	64	10	82	64	10	67
TQK35GUU-E	6	35	0	60	0	70	13	96	75	13	78
TQK40GUU-E	6	40	-12	65	0	80	13	101	80	13	83

* Seals-on-both-sides is standard.

**TQK16G~25G : M3-1 grease fitting TQK30G~40G : A-M6x1
Surface treatment is optional.

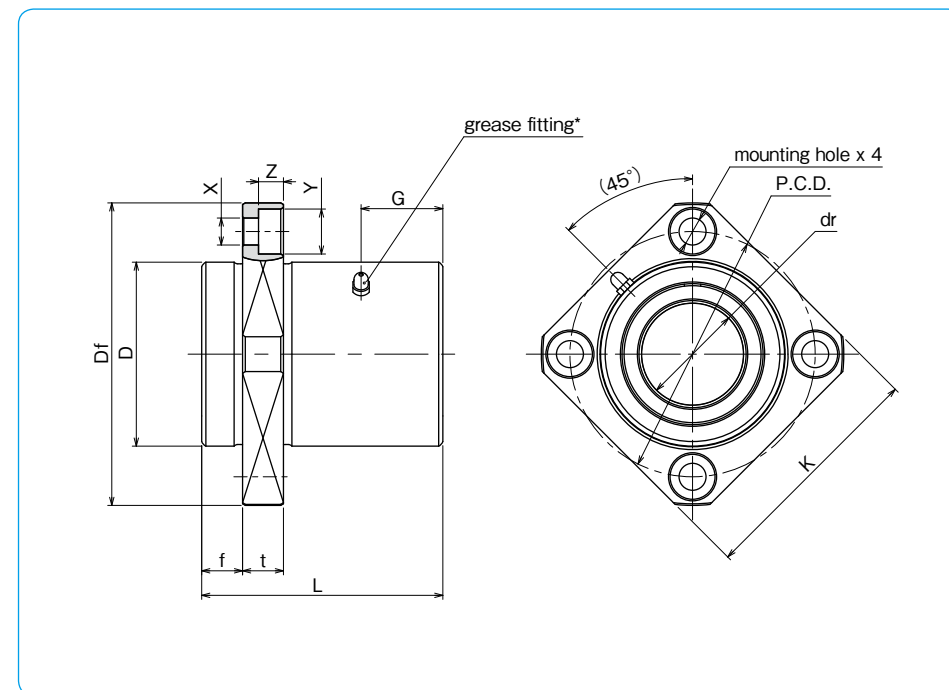

X×Y×Z mm	grease fitting	eccentricity μm	perpendicularity μm	basic load rating		shaft diameter mm
	G mm			dynamic C N	static Co N	
5.5×9×5.1	12	12	12	774	1,180	16
5.5×9×5.1	14	15	15	882	1,370	20
6.6×11×6.1	20			980	1,570	25
6.6×11×6.1	21	20	20	1,570	2,740	30
9×14×8.1	23			1,670	3,140	35
9×14×8.1	27			2,160	4,020	40

1N≐0.102kgf