

# SME TYPE

– Open Block Type –



## part number structure

example **SMSE 25 G UU**

specification SME: standard SMSE: anti-corrosion	inner contact diameter	retainer material blank: standard/steel* anti-corrosion/stainless steel* G: resin	seal blank: without seal UU: seals on both sides
--	------------------------	--	--

\*Size 10 is provided with resin retainer type only.

part number	inner contact diameter mm	major dimensions							
		h mm	E mm	W mm	outer dimensions				
					L mm	F mm	T mm	h <sub>1</sub> mm	θ
SME10GUU	10	15	18	36	32	24	7	6	80°
SME13GUU	13	17	20	40	39	28	8	8.5	80°
SME16GUU	16	20	22.5	45	45	33	9	10	80°
SME20GUU	20	23	24	48	50	39	11	10	60°
SME25GUU	25	27	30	60	65	47	14	11.5	50°
SME30GUU	30	33	35	70	70	56	15	14	50°
SME35GUU	35	37	40	80	80	63	18	16	50°
SME40GUU	40	42	45	90	90	72	20	19	50°
SME50GUU	50	53	60	120	110	92	25	23	50°

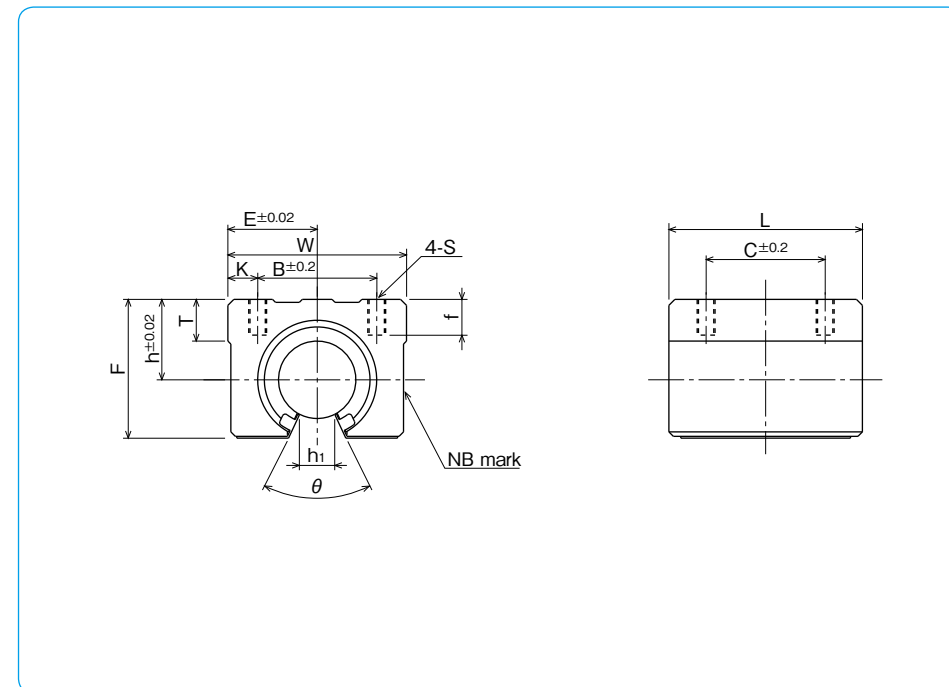

mounting dimensions					basic load rating		* mass g	shaft diameter mm
B mm	C mm	K mm	S	f mm	dynamic C N	static Co N		
25	20	5.5	M5	10	372	549	65	10
28	26	6	M5	10	510	784	100	13
32	30	6.5	M5	12	774	1,180	150	16
35	35	6.5	M6	12	882	1,370	200	20
40	40	10	M6	12	980	1,570	450	25
50	50	10	M8	18	1,570	2,740	630	30
55	55	12.5	M8	18	1,670	3,140	925	35
65	65	12.5	M10	20	2,160	4,020	1,330	40
94	80	13	M10	20	3,820	7,940	3,000	50

\* Mass of resin retainer type

1N≒0.102kgf