

SNW TYPE

- NB Inch Shaft -

part number structure

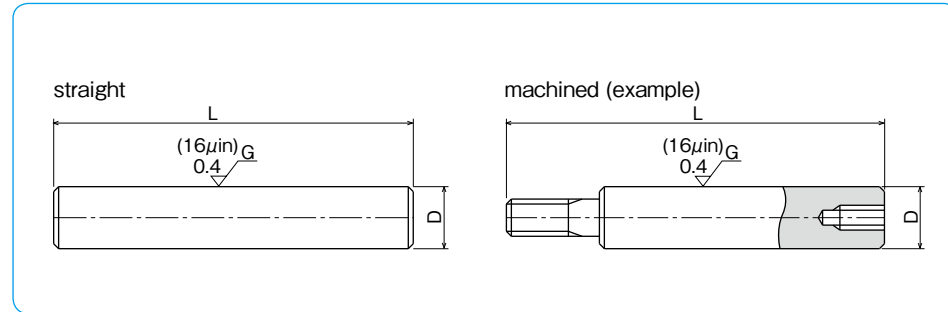
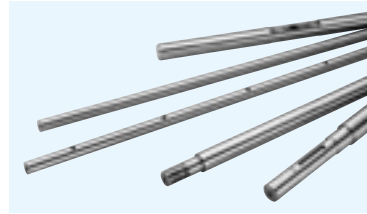
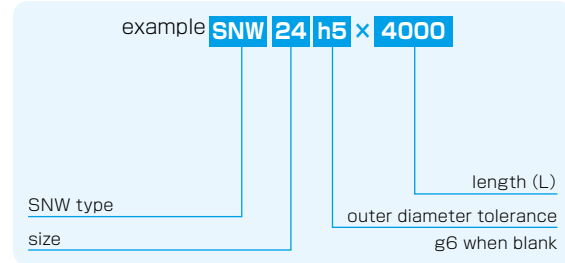

| part number | outer diameter | | length L | mass |
|-------------|-----------------|-------------------------|----------------------------------|----------------|
| | D inch/mm | tolerance g6 inch/µm | | |
| SNW 4 | 1/4 6.350 | -.0002 -.0006 | 3.94 100 ← → 39.37 1000 | 0.014 0.25 |
| SNW 6 | 3/8 9.525 | -5 -14 | 7.84 200 ← → 59.06 1500 | 0.031 0.56 |
| SNW 8 | 1/2 12.700 | -.0002 -.0007 | 7.84 200 ← → 118.11 3000 | 0.056 0.99 |
| SNW10 | 5/8 15.875 | -6 -17 | 7.84 200 ← → 157.48 4000 | 0.086 1.55 |
| SNW12 | 3/4 19.050 | -.0003 -.0008 | 11.81 300 ← → 157.48 4000 | 0.125 2.24 |
| SNW16 | 1 25.400 | -7 -20 | 11.81 300 ← → 157.48 4000 | 0.222 3.98 |
| SNW20 | 1-1/4 31.750 | -.0004 -.0010 | 11.81 300 ← → 157.48 4000 | 0.348 6.22 |
| SNW24 | 1-1/2 38.100 | -9 -25 | 15.75 400 ← → 157.48 4000 | 0.500 8.95 |
| SNW32 | 2 50.800 | -.0004 -.0011 | 19.69 500 ← → 157.48 4000 | 0.890 15.91 |
| SNW40 | 2-1/2 63.500 | -10 -29 | 23.62 600 ← → 157.48 4000 | 1.391 25.00 |
| SNW48 | 3 76.200 | -10 -29 | 23.62 600 ← → 157.48 4000 | 2.003 37.92 |
| SNW64 | 4 101.600 | -.0005/-0013 -12/-34 | 39.37 1000 ← → 157.48 4000 | 3.560 64.02 |

material: high-carbon chromium bearing steel (SUJ2)
hardness: 60HRC (HV697) or more
Tolerances other than g6 are available upon request.

1kg≒2.205lbs

SNWS TYPE

- NB Inch Stainless Steel Shaft -

part number structure

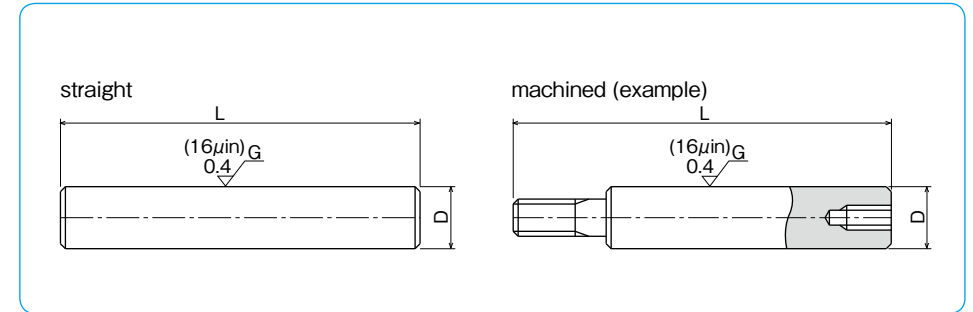
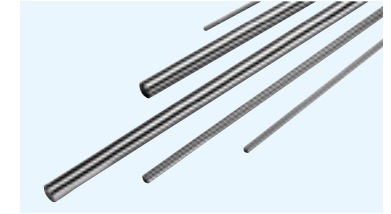
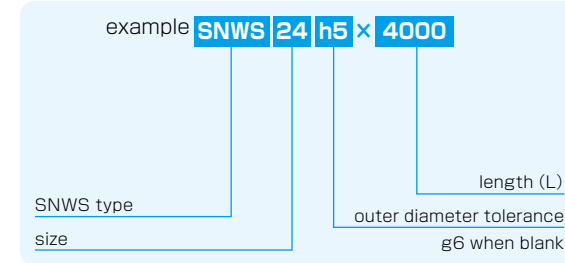

| part number | outer diameter | | length L | mass |
|-------------|-----------------|-------------------------|---------------------------------|----------------|
| | D inch/mm | tolerance g6 inch/µm | | |
| SNWS 4 | 1/4 6.350 | -.0002 -.0006 | 3.94 100 ← → 23.62 600 | 0.014 0.25 |
| SNWS 6 | 3/8 9.525 | -5 -14 | 7.84 200 ← → 39.37 1000 | 0.031 0.55 |
| SNWS 8 | 1/2 12.700 | -.0002 -.0007 | 7.84 200 ← → 98.43 2500 | 0.056 0.98 |
| SNWS10 | 5/8 15.875 | -6 -17 | 7.84 200 ← → 118.11 3000 | 0.086 1.54 |
| SNWS12 | 3/4 19.050 | -.0003 -.0008 | 11.81 300 ← → 157.48 4000 | 0.125 2.22 |
| SNWS16 | 1 25.400 | -7 -20 | 11.81 300 ← → 157.48 4000 | 0.222 3.95 |
| SNWS20 | 1-1/4 31.750 | -.0004 -.0010 | 11.81 300 ← → 157.48 4000 | 0.420 6.16 |
| SNWS24 | 1-1/2 38.100 | -9 -25 | 15.75 400 ← → 157.48 4000 | 0.500 8.88 |
| SNWS32 | 2 50.800 | -.0004/-0011 -10/-29 | 19.69 500 ← → 157.48 4000 | 0.890 15.78 |

material: martensite stainless steel (equivalent to SUS440C)
hardness: 56HRC (HV613) or more
Tolerances other than g6 are available upon request.

1kg≒2.205lbs