

SNT TYPE

– NB Hollow Shaft –

part number structure

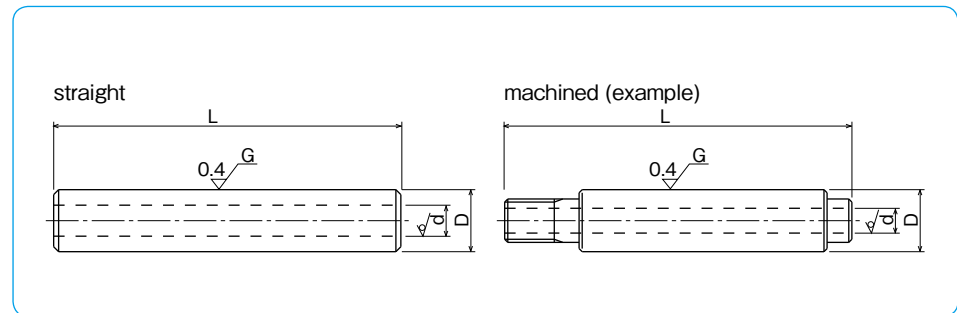
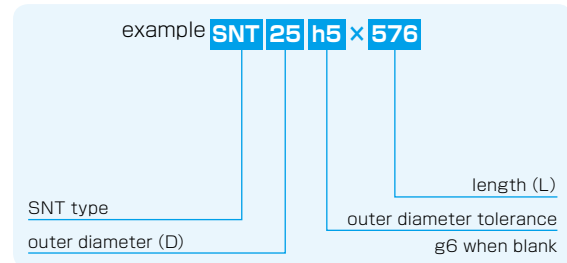

part number	outer diameter		inner diameter	length L		mass
	D	tolerance		L	L	
	mm	g6 μm	d mm	mm		Kg/m
SNT 6	6	-4/-12	2	100	← 400	0.20
SNT 8	8	-5	3	200	← 600	0.34
SNT 10	10	-14	4	200	← 1000	0.52
SNT 12	12	-6	5	200	← 1500	0.73
SNT 13	13	-6	6	200	← 1500	0.82
SNT 16	16	-17	8	300	← 2500	1.18
SNT 20	20	-7	10	300	← 4000	1.85
SNT 25	25	-20	15	300	← 4000	2.46
SNT 30	30	-	16	300	← 4500	3.97
SNT 35	35	-	19	400	← 4500	5.32
SNT 40	40	-9	20	400	← 4500	7.39
SNT 50	50	-25	26	500	← 4500	11.3
SNT 60	60	-10	32	600	← 4500	15.9
SNT 80	80	-29	48	800	← 4500	25.3
SNT100	100	-12/-34	60	1000	← 4500	39.5

material: high-carbon chromium bearing steel (SUJ2)
hardness: 60HRC (HV697) or more
Tolerances other than g6 are available upon request.

NB CENTER-LINED TAPPED SHAFT

A larger diameter shaft can overcome problems in maintaining precision functionality when a high or unbalanced load is applied. A combination of the center-lined tapped shaft together with the SA type support rail is ideal in such cases. (see pages F-18,19) The center-lined tapped shaft is standardized to simplify shaft selection.

part number structure

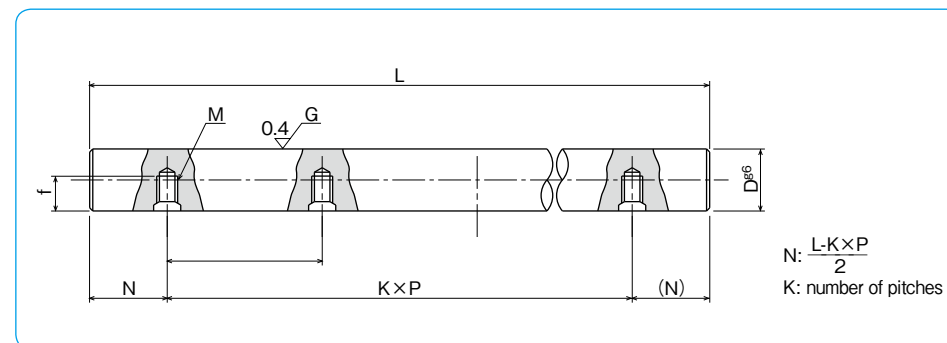
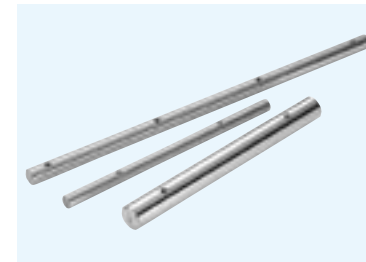
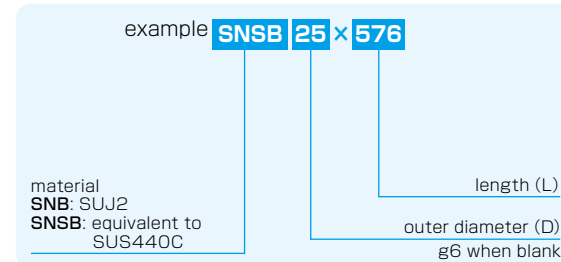

NB Center-Lined Tapped Shaft

part number	outer diameter	tolerance	pitch	screw	tap	maximum
	D	g6*	P	size	depth	length
	mm	μm	mm	M	f	L _{max}
					mm	mm
SNB10	10	-5/-14	100	M4	4.5	1,500
SNB12	12	-6	100	M4	5.5	1,800
SNB13	13	-17	100	M4	6	2,000
SNB16	16	-	150	M5	7	4,000
SNB20	20	-7	150	M6	9	4,000
SNB25	25	-20	200	M6	12	4,000
SNB30	30	-	200	M8	15	4,500
SNB35	35	-9	200	M8	15	5,000
SNB40	40	-25	300	M8	18	6,000
SNB50	50	-	300	M10	22	6,000

material: high-carbon chromium bearing steel (SUJ2)
hardness: 60HRC (HV697) or more
*g6 is a standard tolerance of the outer diameter.

NB Center-Lined Tapped Stainless Steel Shaft

part number	outer diameter	tolerance	pitch	screw	tap	maximum
	D	g6*	P	size	depth	length
	mm	μm	mm	M	f	L _{max}
					mm	mm
SNSB16	16	-6/-17	150	M5	7	2,000
SNSB20	20	-7	150	M6	9	3,000
SNSB25	25	-20	200	M6	12	4,000
SNSB30	30	-	200	M8	15	4,500
SNSB35	35	-9	200	M8	15	5,000
SNSB40	40	-25	300	M8	18	6,000
SNSB50	50	-	300	M10	22	6,000

material: martensite stainless steel (equivalent to SUS440C)
hardness: 56HRC (HV613) or more
*g6 is a standard tolerance of the outer diameter.